



Arctic Manufacturing Ltd.

3323 Hart Highway, Prince George, B.C. V2K 1M8

ph: (250) 962-9631

fx: (250) 962-7500

www.arcticmfg.com

Arctic - Cab-Guard Identification

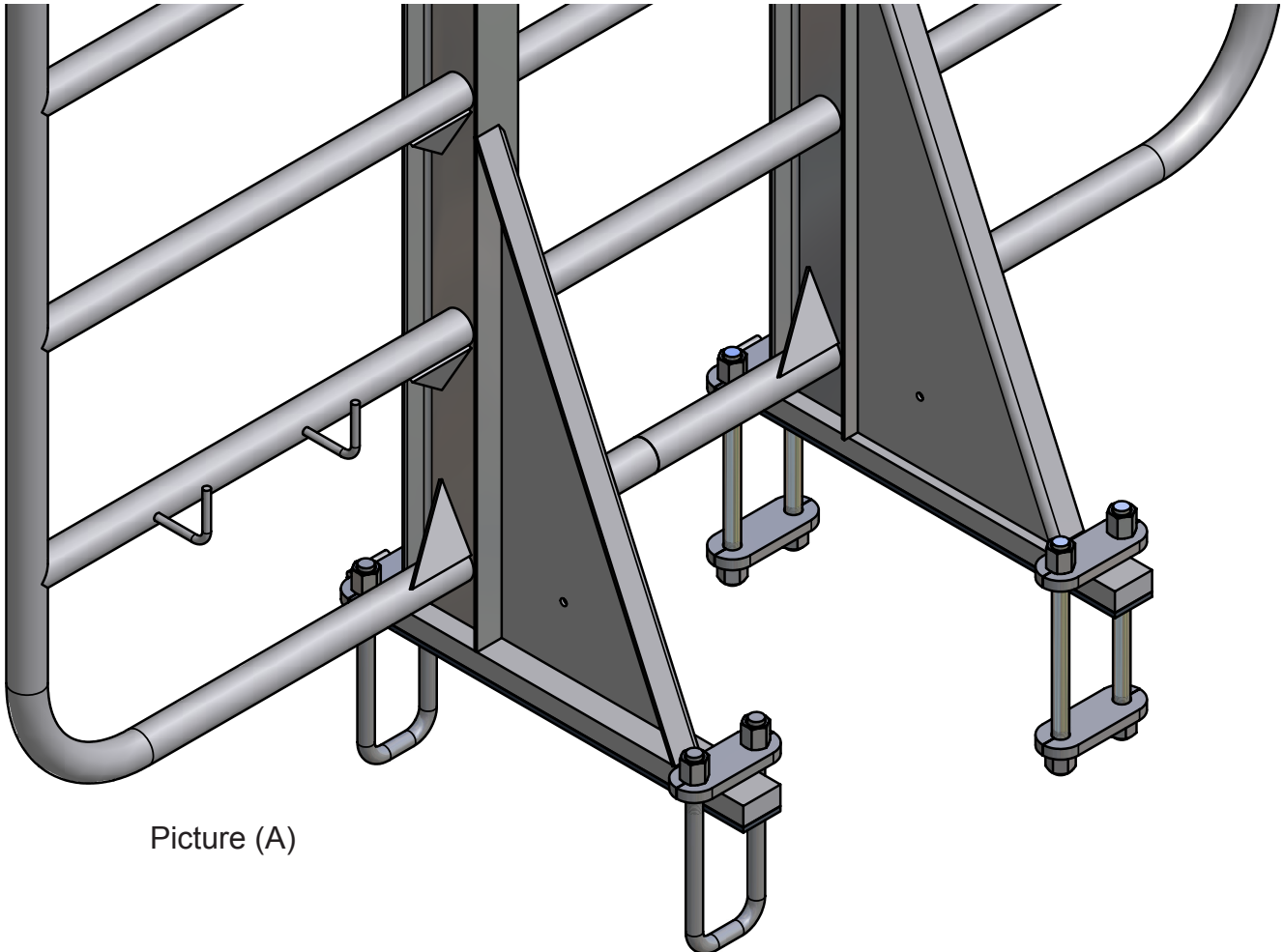

Picture (A)

Earlier Model Cab-guards that were produced for 7/8" u-bolts and rods as shown in picture (A) were produced with out the rear tie plates shown in picture (B). The addition of the rear tie plates over the rear U-bolts to improve the performance with the change to 1" U-bolts. All Cab-guards produced by "Arctic" feature a full formed gusset with the formed legs to the outside. As well, all cab-guards are manufactured with a 6" S @ 12.5 I-Beam shown in picture (C). The dimensions and shape are shown in picture (C). Any cab-guards that have (H) or (W) profile shape uprights are not "Arctic Manufacturing Ltd." Cab-guards. These steel profiles have been used by other manufactures.

As stated in our identification/rating plates, these cab-guard must be mounted using approved U-bolts and hardware. All U-bolts must have smooth inside radius and be free from cracks. All AML2003 and AML2003HD tie plates must be supplied from "Arctic Manufacturing Ltd." and have the flame

cut profile. These plates are flame cut from Hi-Tensile plate and have been "Static Load Tested" to the rating of the cab-guard. The cab-guard must be mounted on AML2001 Rubber Iso Pads. This will reduce any frame rub damage to the top flange of the truck frame. Torque 7/8" U-bolts to 200 ft/lb and 1" U-bolts to 240 ft/lb for clean-oiled U-bolts. Threads must have at least 1 full turn of threads of exposed.

"Arctic" cab-guards have been "Static Load Tested" without truck frame web stiffeners, therefore they are not required for our approved mounting requirements.

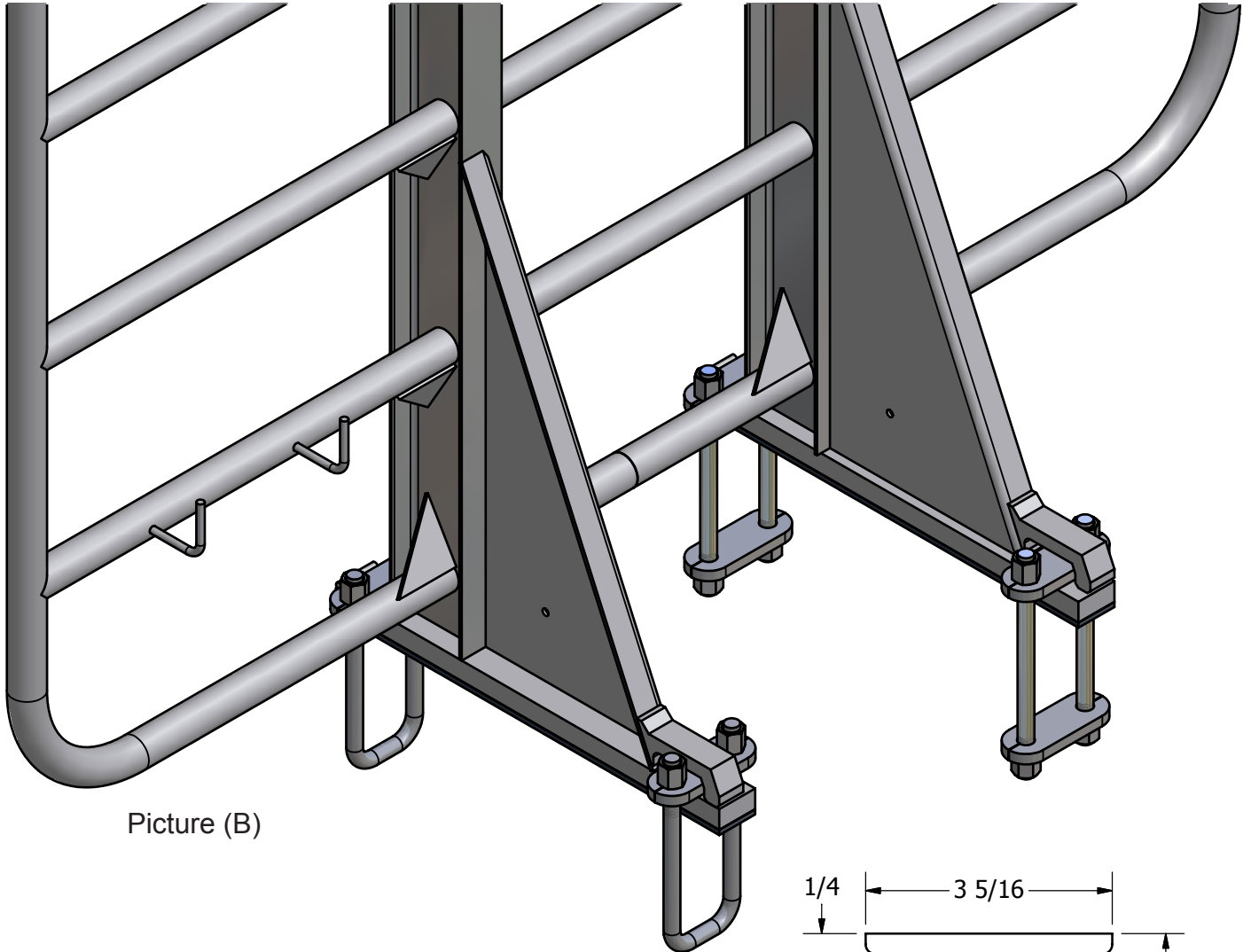

Picture (B)

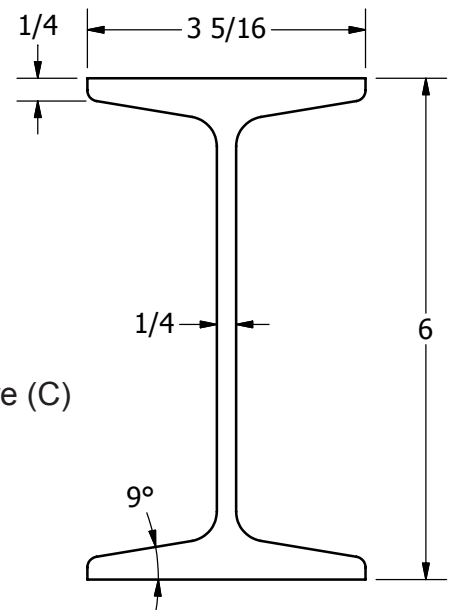

Picture (C)