

ARCTIC

Trailers Inc.

3323 HART HIGHWAY, PRINCE GEORGE, B.C.
Phone: (250) 962-9631 Fax: (250) 962-7500
www.arcticmfg.com



Heavy Duty Heated V-Type Off-Road Sander

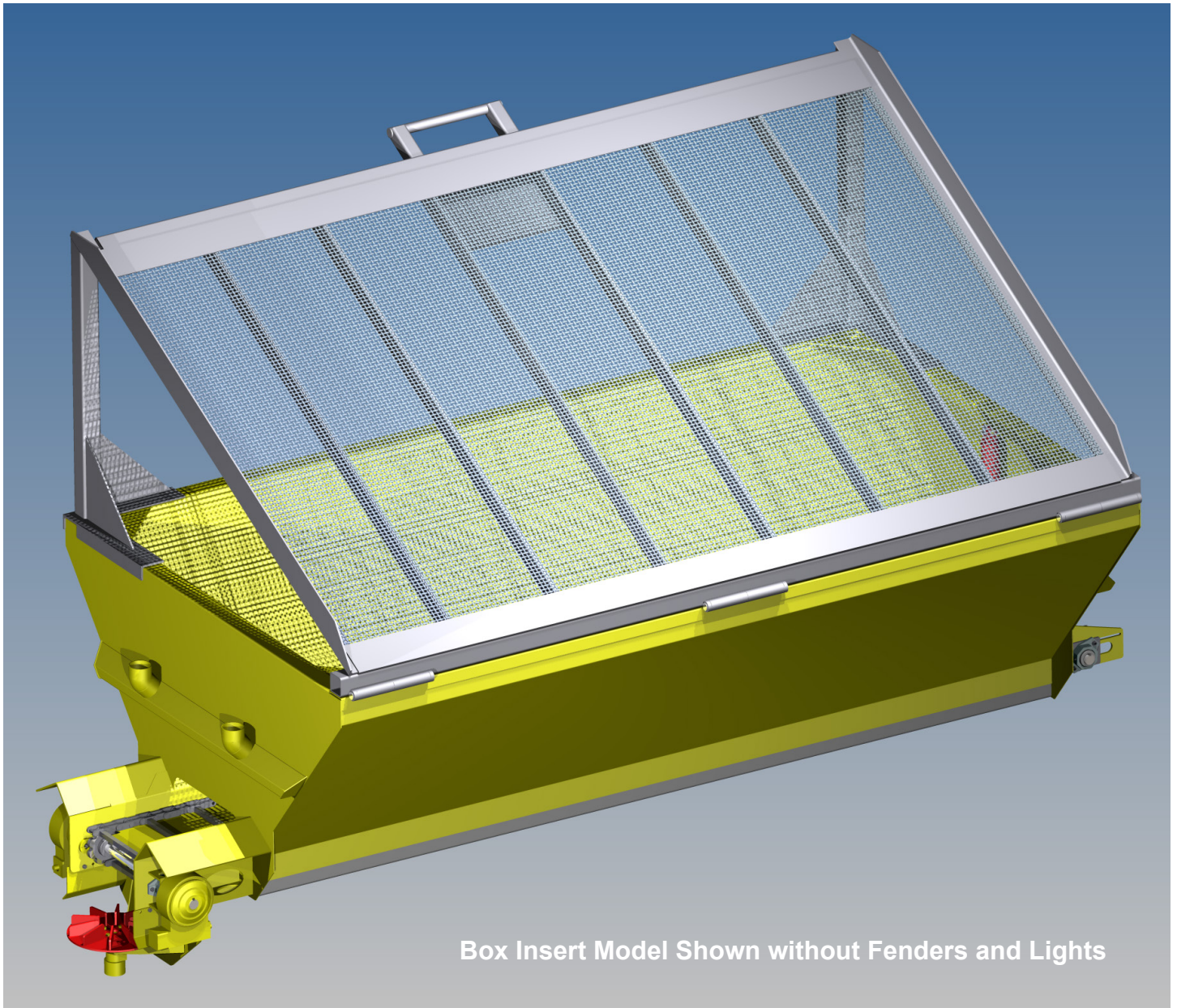

Box Insert Model Shown without Fenders and Lights

Exhaust heated V-Type sander featuring double V-Side walls and floor. QT-100 V-Sides and floor/chain trough. Heavy Duty 88HDX chain with 1 1/4" square QT-100 cross bars. Side wall feature numerous vented "Z-Bar" ribs for even distribution of heating gasses.

Available in either fender/lighting equipped as the primary unit or without fenders and lights to mount inside an existing dump box.

Dual worm drives with 2" shafts. QT-100 material used for drive sprockets. #40 double roller chain used to connect 2" Worm Drive shaft to central chain shaft. Grease type hydraulic chain tensioners employed.

Rear exhaust ducts directed upward to reduce "fog" from formed at rear of unit, improves visibility in cold conditions.

Internal hydraulic double acting breaker bar inside to break-up material cavity dome.

Angled covers over drives/motors protects housing from material falling over end of "Grizzly".

"Grizzly" features heavy duty

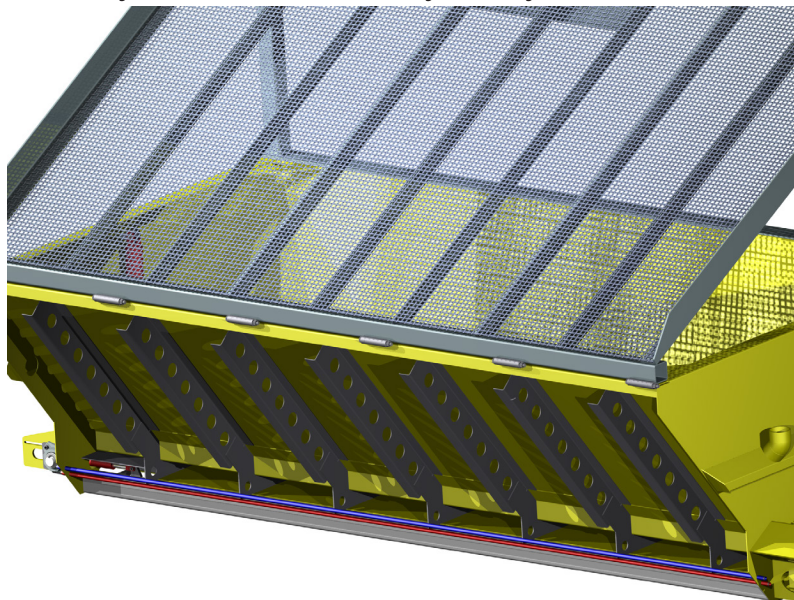
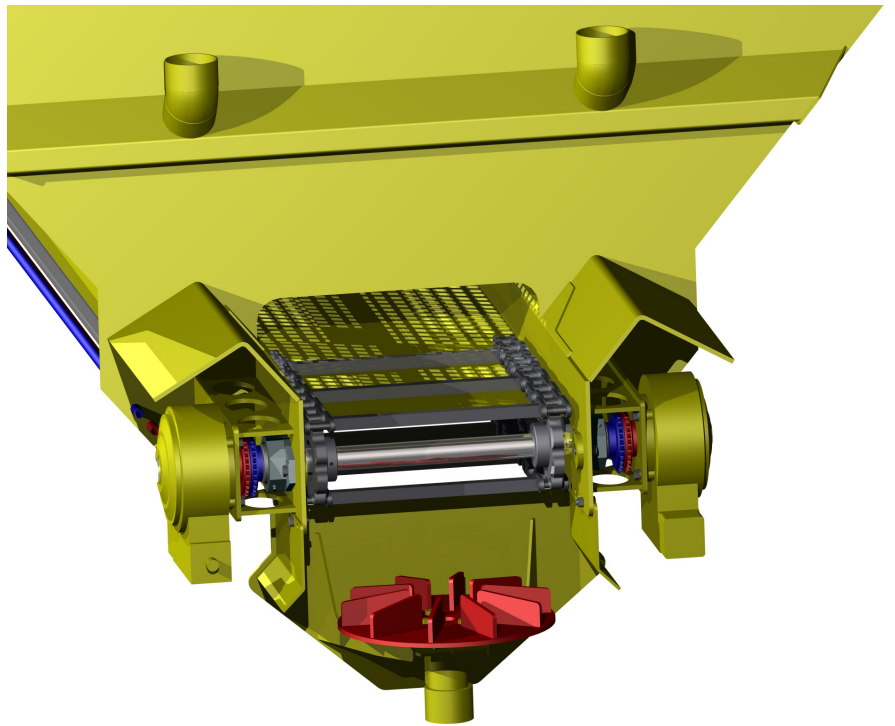

hinges along side to allow "Grizzly" to be "Tipped" for cleaning. Loader bucket lift plate as well as for "Hoe" use. 2" x 2" x 1/2" round bar woven grating used with numerous stiffener ribs. Front and Rear of "Grizzly" have 6" vertical containment edges to help reduce material from falling over the ends.

All units media blasted, then primed with 2-part DuPont epoxy primer and Imron polyurethane paint.