

ARCTIC

MANUFACTURING LTD.

3323 HART HIGHWAY, PRINCE GEORGE, B.C.
Phone: (250) 962-9631 Fax: (250) 962-7500
www.arcticmfg.com



ED3603

Tub-Type Tridem End Dump



Basic Equipment

- Extreme Hi-Tensile 130,000 psi Sides • 100,000psi Front & Rear Plates • AR400 Floor • 89 1/2" Inside Width, 48" High Tail-Gate, • 2 1/2" Machined Rear Tipping Sill Hinge Pins • Manual Override Solenoids for Suspension Dump and Tail-Gate Trip •

Optional Equipment

- Michel's "Gravel-Guard" Tarp System • Standard Gate Opening Optional • Automatic Air Lift on Axles #1 & #2 • LED Lighting • Electronic Scales • Fenderco HD Poly Fenders • Hydraulic Hi-Lift Gate • Push Block • Power Tarp System • Alum Wheels •

Specifications

ED3603 36' End-Dump Tridem Tub

Hydraulic Requirements:

- Main Box: 40 gpm @ 2000 psi Max
41.3 Gal Main Ram Volume
- Hi-Lift (optional): 5 gpm @ 2000 psi Max
.2 Gal Hi-Lift Ram Volume

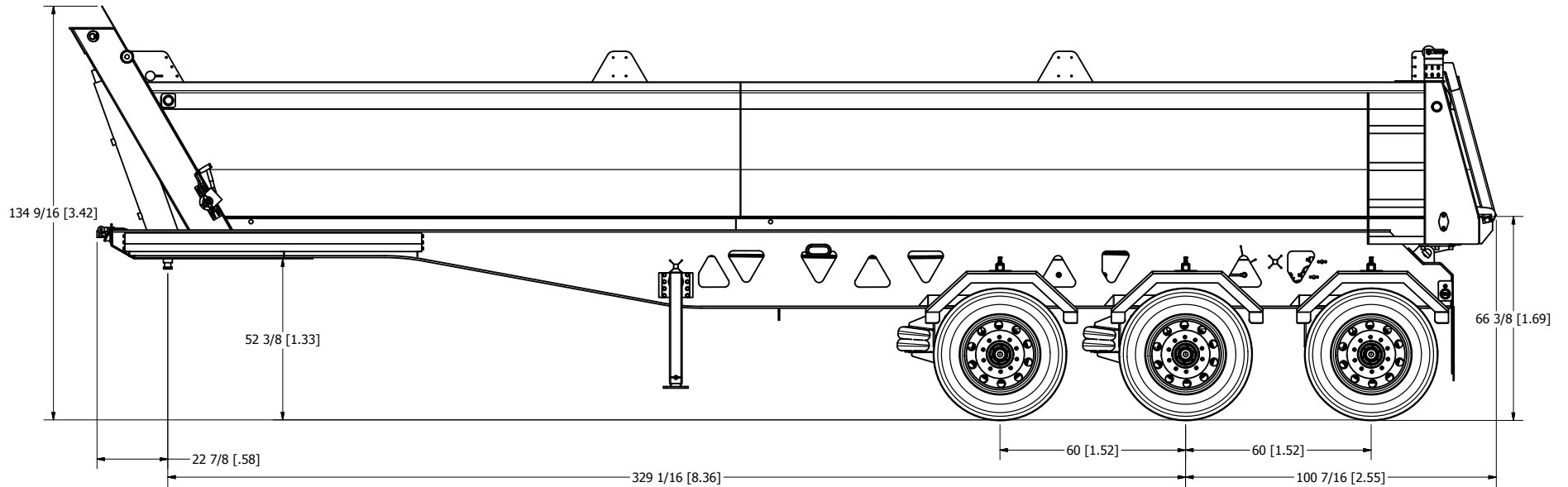

- Specs:
- Capacity: 33 1/2 cu/yd
- Dimensions ID: 36' L x 89 1/2" W x 43 7/16 H
- Weight: 8,410 kg
- Tip Angle: 41°